

# ASMS

# SPRUE EXAMINER



Tim Robb's 1/144th Electra



Detail and Scale's F2H Banshee  
Pt 2  
by Floyd Werner



*What's UP? Old Rumors & New Kits Tracked Topics*

News • Articles • Features • Opinions • Advice •

# CONTENTS

Page 3 The President's Soapbox

Page 4 House Cleaning

Page 5 Tim Robb's L-188 Lockheed Electra by Tim Robb

Page 9 Detail and Scale F2H Banshee pt 2 by Floyd Werner

Page 11 LionHeart Update by Rudy Cline.

Page 12 What's Up Wid You?

Page 17 Old Rumors and New Kits:

Page 17 New and In View by Ron McCracken

Page 25 Shipping News - by Rick Herrington

Page 32 Tracked Topics by Panzer Lehr

## ASMS Officers & Chairpersons

Tim Robb - President; [president@austinsms.org](mailto:president@austinsms.org)

Ron McCracken - Vice-President; [vicepresident@austinsms.org](mailto:vicepresident@austinsms.org)

Aaron Smischney - Finance Minister; [treasurer@austinsms.org](mailto:treasurer@austinsms.org)

Seth Souza - Secretary; [secretary@austinsms.org](mailto:secretary@austinsms.org)

Rick Herrington - Newsletter Editor; [editor@austinsms.org](mailto:editor@austinsms.org)

Show Coordinator; [showcoordinator@austinsms.org](mailto:showcoordinator@austinsms.org)

Mike Gilsbach - Webmaster; [webmaster@austinsms.org](mailto:webmaster@austinsms.org)

Ben Morton - IPMS/USA Coordinator; [chaptercontact@austinsms.org](mailto:chaptercontact@austinsms.org)

## Our Sponsors

Phil Brandt (in memorium)

Eric Choy Angela Forster

Jeff Forster Russ Holm

Rick Willaman Jack Johnston

Mike Krizan Rick Herrington

Dragon's Lair comics and fantasy



[www.austinarmorbuilders.com](http://www.austinarmorbuilders.com)



[www.kingshobbyshop.com](http://www.kingshobbyshop.com)



[www.wmbros.com](http://www.wmbros.com)



[www.ctsms.org](http://www.ctsms.org)

## IPMS/USA Support the Troops Initiative

The IPMS/USA initiative was established to provide model kits, supplies and reference materials to our servicemen and women serving in combat zones, recovering in hospitals, and rehabilitating in specialized facilities. The program is expanding into other areas as well. Some local programs take place in USO facilities, some are centered around active duty personnel and are scattered across the country. The IPMS/USA Support The Troops program is still going full-tilt. The national program director is Jon Emery. Jon is accepting any and all contributions and is sharing them with all of the active programs around the country.

[www.models4troops@gmail.com](mailto:www.models4troops@gmail.com)



[www.austinsms.org](http://www.austinsms.org)

Austin Scale Modelers Society (ASMS) is a chartered chapter of International Plastic Modelers Society (IPMS/USA). ASMS meets on the third Thursday of each month. Annual dues for full membership are \$25/individual or \$30/family. The views expressed in this newsletter are those of the authors. It is intended for educational purposes only.

ASMS does not endorse the contents of any article.

# PRESIDENT'S SOAPBOX

BY TIM ROBB



Greetings modelers.

May 4th was a banner day for ASMS as our members attended two events that day. Five of us attended Model Mania in Houston as entrants plus three more as vendors.

The same day we had four representing us at Pioneer Flight Museum's spring Fly -in event in Kingsbury. Next up in NCT's show May 25 in Grapevine. Who wants to go? I do. Carpooling is safe ---- no tunnels. :)

Go build a Model!  
Tim





# HOUSE CLEANING



## ASMS MEETING

Third Thursday each month  
6:30 pm - 8:45 pm  
at Mr. Tramp's Sports Pub  
8565 Research Blvd  
Austin, TX 78758

**No Reservations Necessary!**

### *ASMS Club Dues Are Due!*

Annual ASMS club dues are \$25.00/individual  
or \$30.00/family.

You may bring your dues to a club meeting or remit  
same to ASMS, 1928 Dragonfly Loop, Bastrop, TX  
78602.



### Events

May 25 – Scalefest 2024

Time: 9 AM - 5 PM

Location: Grapevine Convention  
Center

1209 South Main Street, Grape-  
vine, TX 76051

Theme: Red

### Club Quarterly Contests

### Monthly Meeting Presentations:



# Tim Robb's 1/144th Lockheed L-188 Electra

by Tim Robb.



This is the Minicraft 1/144 Lockheed L-188 Electra II. It goes together quickly and I was into the bodywork and paint prep stage quickly.

I need to mention here that I almost always have half a dozen or more models in progress. This Electra was not at any time the top priority model on my workbench so it took a couple of years calendar time to finish. But I always tell myself that a model can't be finished if it's never started and I think I have a pretty good track record for not completely abandoning started projects.

So one day I looked up and after all the sanding, painting, re-sanding, polishing, and re-painting Mr. Electra was ready for decals. The kit came with decals for Eastern Airlines and KLM, both very attractive schemes. The decals, however, were very badly out of register and unusable. I knew that from the beginning and found Braniff International makings on line from Vintage Flyer Decals. Yes, I saw many Braniff Electras at Love Field so this was a good choice for me.



Some years ago I built a DeHavilland Comet model with a white top to the cabin. I painted it flat white and then glossed it up with several coats of Future prior to decalling and again post decalling. When finished my white had turned to a creamy yellow and I was disappointed with my result. Since then I have primed with flat white and then painted with gloss white Testor's enamel in the little square bottles that cost fifteen cents in the 1960s (I remember when the price increased from twelve to fifteen).

I let the gloss enamel dry at least three days and then the decals go straight onto the gloss white and get one thin coat of Future for sealer, and that not all over just over the decals. This gives a nice white airliner fuselage. To put on the cheat line decals I cut them into smaller parts, five parts per side on this Electra. I also cut the Braniff International Airlines decal of the fuselage side into three parts, one for each word. I also decal only one side of the model at a time, waiting a couple of days for the other side. A tricky part to decalling an airliner is the nose where all the cheat lines and cockpit window decals come together. The after-market decals I've used all included some extra decal film of the color needed so this area can be pieced together. I haven't mastered this, some decal overlaps are there to see on close inspection.





My Electra model is mostly out of the box. The exceptions are I cut landing gear doors from thin plastic sheet to replace the thick clunky kit parts.

I also sanded the tips of the prop spinners flat and then drilled a little hole there.

You could see this detail on the Electra from the rooftop observation deck at Love Field.

If you haven't before, try an airliner model. They are fun and a nice change of pace. I am well pleased with this one.

Go Build a Model!  
Tim





# Detail and Scale F2H Banshee Part 2: A review

by Floyd Werner.

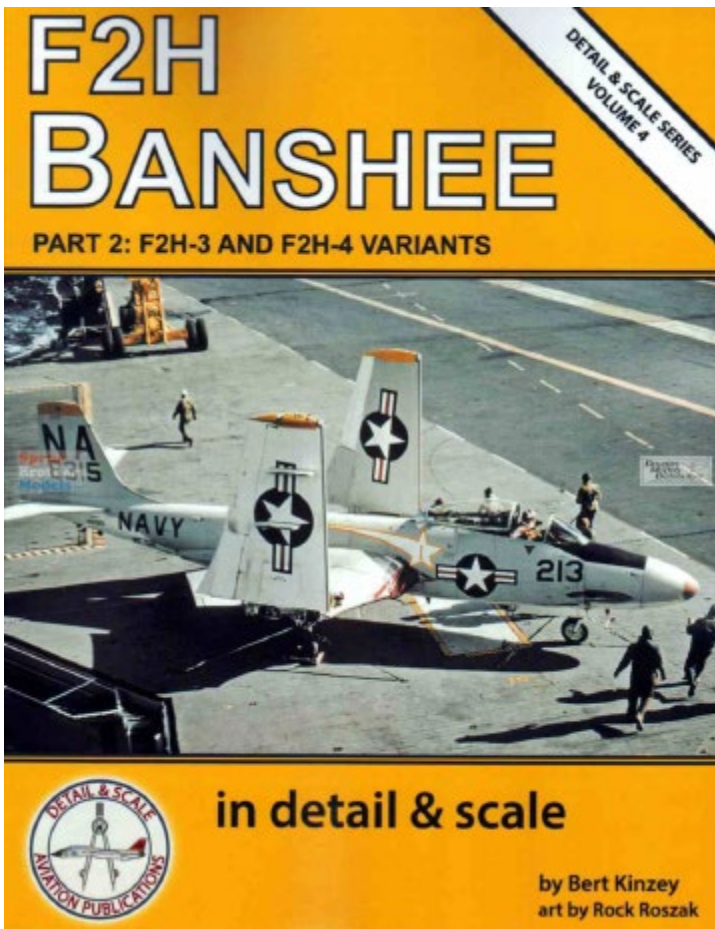

Note: The profiles on these two pages illustrate the variety of paint schemes and markings used on F2H-4s. They are arranged in numerical order (based on squadron designators). All profiles are by Rock Roszak.



Undoubtedly the most colorful squadron markings to ever adorn "Big Banjos" in the overall Gloss Sea Blue scheme were those used by the "Red Rippers" of VF-11. A red streak was painted across the canopy, and it was outlined in white. The squadron's over-the-head marking was on each side of the forward fuselage with red lightning bolts, outlined in white, extending down and aft from there. Additional lightning bolts were on the upper fuselage. The fin cap and the fin tab on the rudder were also painted red. The squadron insignia was painted on the forward fuselage below the aft end of the canopy.



F2H-4, BuNo. 127595, displays the markings used by the "Cavalo" of VF-22 on their gray over white Banshees in 1957. The top of the vertical tail was painted red, and red lightning bolts were on the tip tanks. Although "Big Banjos" in the gray over white scheme usually had radomes painted in those colors with only the very front of the radome being left, the entire radome was the tan color on this aircraft.



VF-71 was the only fleet squadron to initially fly the F2H-3 version of the Banshee, then later change to the F2H-4 for its final deployment. F2H-4, BuNo. 127580, displays the markings used by the "Hell's Angels" on their gray over white Banshees for that final deployment aboard USS RANDOLPH, CV-15, during late 1953 and early 1954. These included a red band near the top of the vertical tail and red stripes on the rudder.

By comparison to VF-11's markings, illustrated in the first profile above, those used by VF-22 were quite simple, consisting only of a red fin cap and red on the wing tips. The squadron insignia was located well forward on the nose. BuNo. 127623 displays these simple markings. The "Iron Man" later added red flashes with white stars to each side of the forward fuselage and to the wing tanks. These flashes were outlined in white. A color photograph of VF-22's F2H-4s with these actual markings can be found in the Overall Gloss Sea Blue section of the Banshee Paint Schemes chapter.



20

The Banshee Part 1 was released in 2016 by Detail & Scale (D&S) which covered the early 'short' variants from the prototype to the F2H-2. This volume picks up where that left off and covers the Big Banshees, the -3 and -4. Typical of the whole D&S series of books this softbound book is everything that a model builder would need. Printed on 102 pages of high-quality paper printed by Amazon on request, this book has over 280 beautiful and clear full photos with 170 in full color. Noted historian and modeler, Bert Kinzey has produced another in a series of books that will be the reference for this naval fighter. To accompany the text are 15 beautiful color profiles done by noted artist Rock Roszak.

This winning combination has produced a fantastic reference book. Starting with the developmental history, we are treated to what made the Big Banjo so much different than the earlier variants. This is just a warmup to the individual variants. There are some colorful options in markings for these aircraft, including the Canadian use of the aircraft. So colorful were the paint schemes that there is a special chapter dedicated to them. Everything from overall GSB to Natural metal, and then aluminum paint, to white and light gull grey. So, they are very colorful, especially when you add in the squadron codes and markings.

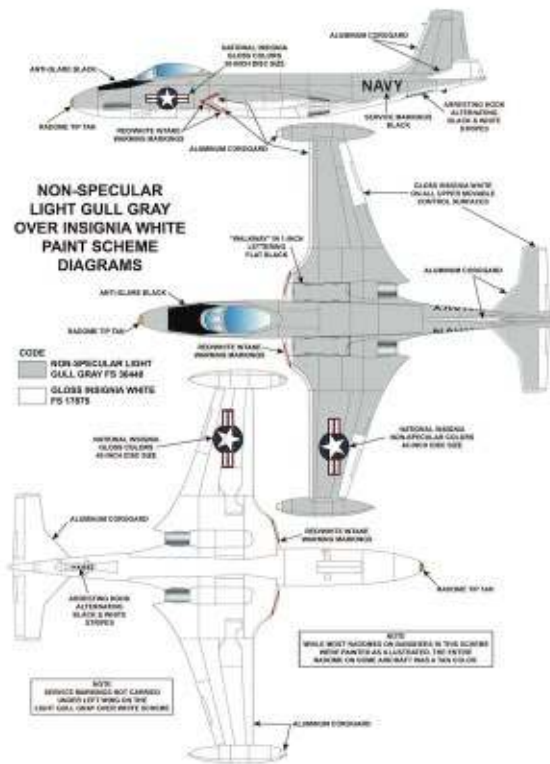

The standard application for the Non-Specular Light Gull Gray over Gloss Insignia White paint scheme and its markings are illustrated in this artwork. However, as the photographs in this section show, there was considerable deviation from the standard on many aircraft. (Artwork by Rock Rozak)

45

**NATURAL METAL FINISH**



An early F2H-3 assigned to VF-141 is ready to launch from Cat 2 aboard USS RANDOLPH, CVN-15, in 1954. The oldest shades of metal are evident on the natural metal surface. Magnesium panels, non-cold aluminum panels, and fiberglass surfaces were painted with aluminum lacquer. (NAMM)



Specifications for the natural metal scheme called for NAVY to be painted in large black letters under the left wing. The F2H-3 was assigned to Composite Squadron THREE (VC-3). (SeaView Collection)

34

Then comes the part that D&S are known for, the detail photos. Starting in the cockpit and working their way around the airframe the modeler will find this section particularly useful. Of course, armament options are included as well.

The modelers section is the part of the book that set Detail & Scale apart. This section covers, 1/144th, 1/72nd and 1/48th scale models.

**MODELERS SECTION**



Very few kits of the F2H-3 and F2H-4 Banshees have been released. Today, only the Miniwing resin kit, shown at the center in this photograph, is available in 1/144<sup>th</sup> scale. At left is the HobbyCraft 1/72<sup>nd</sup> scale model, and at right is the Academy reissue of the HobbyCraft kit. The 2017 release by Academy is still available as of this writing, and although it has many shortcomings, no other 1/72<sup>nd</sup> scale injection molded kit of the "Big Banjos" has ever been produced. (Kinzey)

**General Comments**

The F2H-3 and F2H-4 all-weather interceptor variants of the McDonnell Banshees are subjects that have not been covered well by scale model kit manufacturers. This is unfortunate, because the "Big Banjos" were the first all-weather jet interceptors to be produced for the U. S. Navy and Marines in considerable numbers. Only one kit has been issued in 1/144<sup>th</sup> scale, that being the resin offering from Miniwing. Likewise, only one injection molded kit has been released in 1/72<sup>nd</sup> scale, and that is the HobbyCraft kit from Canada. It leaves a lot to be desired when it comes to detailing and accuracy. It has also been issued under the labels and Academy labels. When it comes to 1/48<sup>th</sup> scale, no injection molded kit has ever been released of the "Big Banjos." Collect-Aire issued a resin kit in 2003, but it is no longer generally available. Kitty Hawk announced a forthcoming 1/48<sup>th</sup> scale kit of the F2H-3/4 in the mid-2010s, but it has never been produced. After the release of their F2H-2/2P variant in 1/48<sup>th</sup> scale, which was plagued with numerous and obvious inaccuracies, it appears doubtful that the F2H-3/4 kit from Kitty Hawk will ever be produced. Detail & Scale had delayed the release of this publication for several years in hopes of including the Kitty Hawk F2H-3/4 kit in this Modelers Section, but since it looks unlikely that it will be released, we have decided to go on and publish the book. No injection molded or resin kit of the F2H-3/4 has ever been issued in 1/32<sup>nd</sup> scale.

As of early 2021, the Miniwing 1/144<sup>th</sup> scale resin kit and the 2017 Academy reissue of the old HobbyCraft kit were generally available. However, modelers are still in need of quality and accurate kits of the F2H-3/4 Banshees in 1/72<sup>nd</sup>, 1/48<sup>th</sup>, and 1/32<sup>nd</sup> scales.

92

**KIT REVIEWS**

**1/144<sup>th</sup> Scale Kit**

**Miniwing F2H-3**

Although Miniwing labels the box as an F2H-3, it can also be built as an F2H-4. The kit comes with decals for an aircraft from VF-11 and alternate markings for a Canadian Banshee assigned to VF-870. The resin kit consists of several major pieces, including the fuselage, right wing, left wing, right and left horizontal tails, and two external tip tanks. Smaller items are molded on a single base and include the nose gear strut and wheel, the left and right main gear struts and wheels, doors for the landing gear, the vertical part of the ejection seat, and the bumper skid. Other Miniwing kits we have built have had vacuumformed canopies, but this one has the canopy molded in clear plastic. All parts are relatively free of flash, and the shapes and outlines are all reasonably accurate. The one noticeable issue with regard to shape accuracy is that the lower cannon fairings on the sides of the forward fuselage are too big.

For a model this small, several items that are specific to the F2H-3/4 are not provided in the kit, because they would be easily broken if cast in resin. These include the pilot probe, the fuel vent, the small scoop near the top of the leading edge of the vertical tail, and the eight pylons under the wings. The instructions show the two outboard pylons that go under the right wing, but the parts are not in the kit, and there is no instruction to make them from plastic card. Although these pylons were not always present on the real aircraft, in most cases they were, and all eight are easy to add from card stock. The

What more could you ask for in a reference book? Nothing. This is the best book on the Big Banjos. Lots of historical photos, drawings, profiles, and plenty of detail shots that will prove very useful for the modeler.

Highly recommended

You can obtain your copy by visiting their website at [www.detailandscale.com](http://www.detailandscale.com). If you order the printed copy, you will be redirected to the Amazon page to purchase it.

The book is also available in Apple books and Kindle format for less at the same place

# LIONHEART

## — H O B B Y —

Here's this month's featured products from Lion Heart.

1/48 Eduard #11181 P-51B Mustang Overlord Dual Combo

1/48 Eduard #Roo19 P-51B Mustang Royal Class Dual Combo

1/48 Eduard #82107X P-51B Mustang Over-trees

1/35 Rye Field Model #5110 SdKfz.234/2 Puma

1/16 Takom / Andy's HHQ #008 M8 Greyhound

Detail & Scale Publications P-38 Lightning Part 2: P-38J through M

1/48 Great Wall Hobby #4829 A-10C Thunderbolt II

1/72 Modelsvit #72025 Mirage 2000D

1/72 Trumpeter #1641 A-6E Intruder

1/25 AMT #1389 Dodge Pickup "Touch Tone Terror"

1/25 MPC #1004 1973 Mercury Cougar

1/25 MPC #1003 1979 Chevy Nova

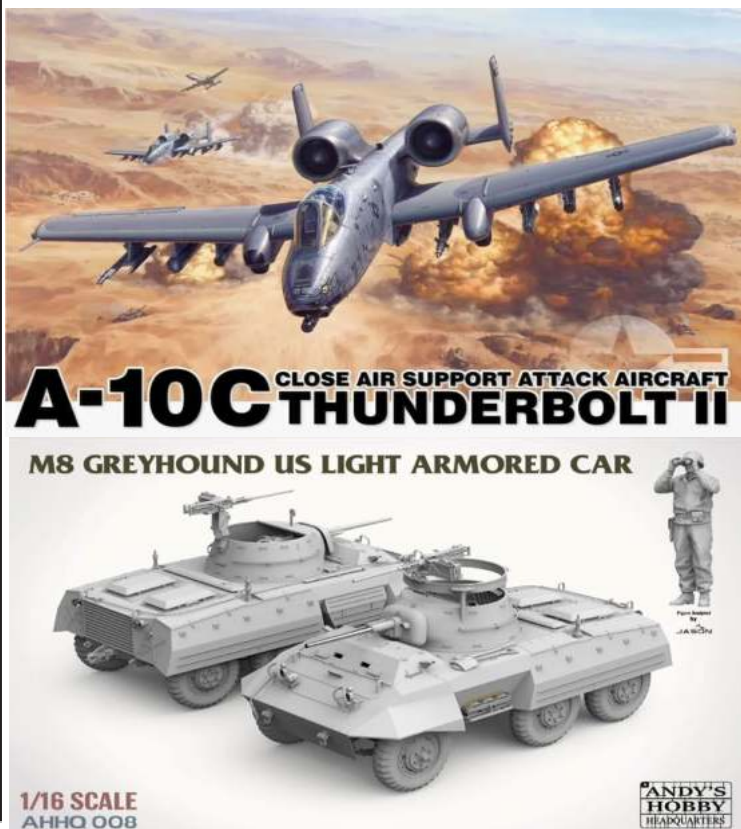

# What's Zip wid You?

ASMS/Bill Delk sponsors an on-line ZOOM meeting with whoever wants to join us to talk about models and life. It happens almost every Sunday at 4:00.

Contact Bill Delk to have him send you a link to be able to get into the meeting.  
Everyone is welcome.

Bill Delk`s e-mail address  
[Falconfyredeuce@gmail.com](mailto:Falconfyredeuce@gmail.com).



Austin Scale Modelers asupported the Houston Show this year. Here's the group that attended.



Tim, Pete, Ian, Sam and Jackson had a great time and got to experience IPMS's new judging technique first hand.

Lots of great models at the meeting this month. Let's start off with contributions from Bob Bethea. Bob and Eric Choy just returned from the AMPS nationals where they gave a presentation on ground work.



Jackson Hunter shared a couple of projects with the group. The first is some Verlinden Panzer Grenadiers.



The grenadiers will later be posed on a Tiger 2 that Jackson is working on.  
Jackson also brought in a Dilanza Sol Bandai Gundam in 1/144. Jackson affectionately named it Blueberry.



Fred Wang brought in his High Grade GM Spartan. This is a 1/144th Bandai kit.



Jorge Martins brought in his Special Hobby 1/72 Dornier DO-27A4 with Shapeways 3D printed Matra RL-181 Rocket Pods.



Mike Gilsbach shared his Tamiya 1/48 M4A38



Tim Robb brought in his 1/48 Hobbycraft Sea Fury.



Steve Anthony brought in an impressive diorama somewhere in the Huertgen forest.

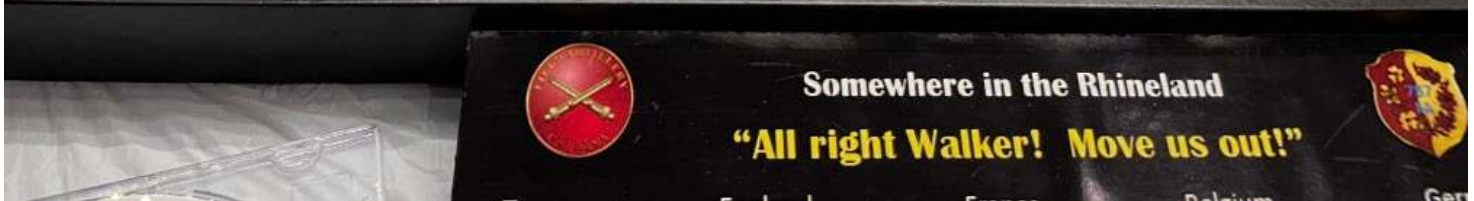

Steve's diorama was a comemorative gift to his father in law. His older brother is the driver/tech sargeant.



First up from Ron McCracken is a 1/72 Italeri YF-23. Ron re-scribed the panel lines and scratch built the engine intakes.



Charlie Hauptrief brought in his 1/350 scale AFV Club Type VII U-boat.  
Rick Herrington brought in his 1/35 Trumpeter BMD-3.



Next from Ron is a Special Hobby 1/72 Brewster Bermuda.



Jackson Hunter shared his Games Workshop Necrons.



Ron also shared his 1/72 Bell UH-1N by Fujimi.



Last from Ron is an Emhar 1/72 MsDonnell F3H-2.



Gene Myers won Model of the Month with his Tamiya McDonnell Phantom II F4D in 1/32 scale.

Gene made custom ejection handles and used Eduard photo etch to enhance the aircraft.





## Old Rumors and New Kits

### New and In View Aircraft

by Ron McCracken

Offerings for May are mostly in the two predominant scales of 1/48th and 1/72nd. As far as brand new-tool offerings, there are two in 1/48th scale from Eduard and ICM. Otherwise everything in view for May is a re-pop of an existing kit, generally with a new set of decals.

#### 1/48th Scale:

Eduard has released a new-tool special edition “Overlord: D-Day Mustangs Dual Combo” featuring two P-51B/C kits and 10 different markings for aircraft that participated in the D-Day invasion.



Eduard has re-released their Spitfire Mk.IXc late in a Weekend Edition kit with four markings options.



Hasegawa has re-released their Ki-84 Hayate in 51st Flying Squadron markings.

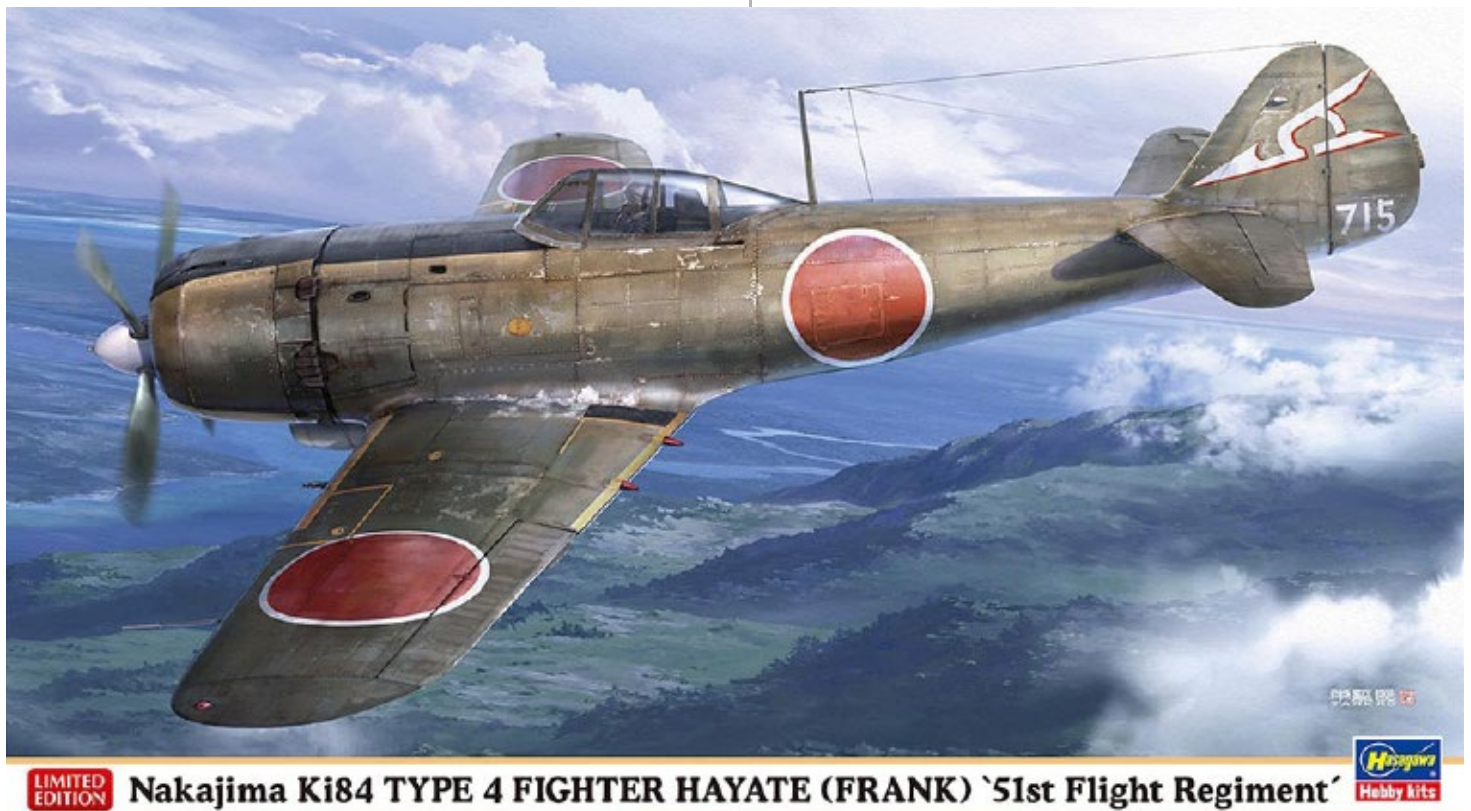

HobbyBoss has re-released their MiG-35 as a Fulcrum F with some new parts.



ICM has released a new-tool B-26B-55 Marauder (the last production run of the B model) with three markings options for D-Day participants – one O.D. finished aircraft, and two bare-metal schemes.



Kinetic has re-released their F/A-18A Hornet in RAAF Operation Okra markings.



Kinetic has also re-released their F-16A/B kit as a Block 20 RoCAF 70th Anniversary “Flying Tigers” kit.



Kinetic has also re-released their IA-58 Pucara in RAF markings, with new decals.



Revell has re-released their Do 335 Pfeil, unsure what, if anything, has been updated since the previous release (2010).



1/72nd Scale:

Eduard has re-released their Spitfire Mk.IXc late in a Weekend Edition kit.

**eduard**

**WEEKEND**  
edition



**Spitfire Mk.IXc late**

scale **1/72**

Fine Molds has re-released their F-15DJ in Aggressor markings.



Fine Molds has also re-released their F-15J in Aggressor markings.



Hasegawa has announced a re-release of their Ki-67 Type 4 Hiryu (Peggy) with new markings.

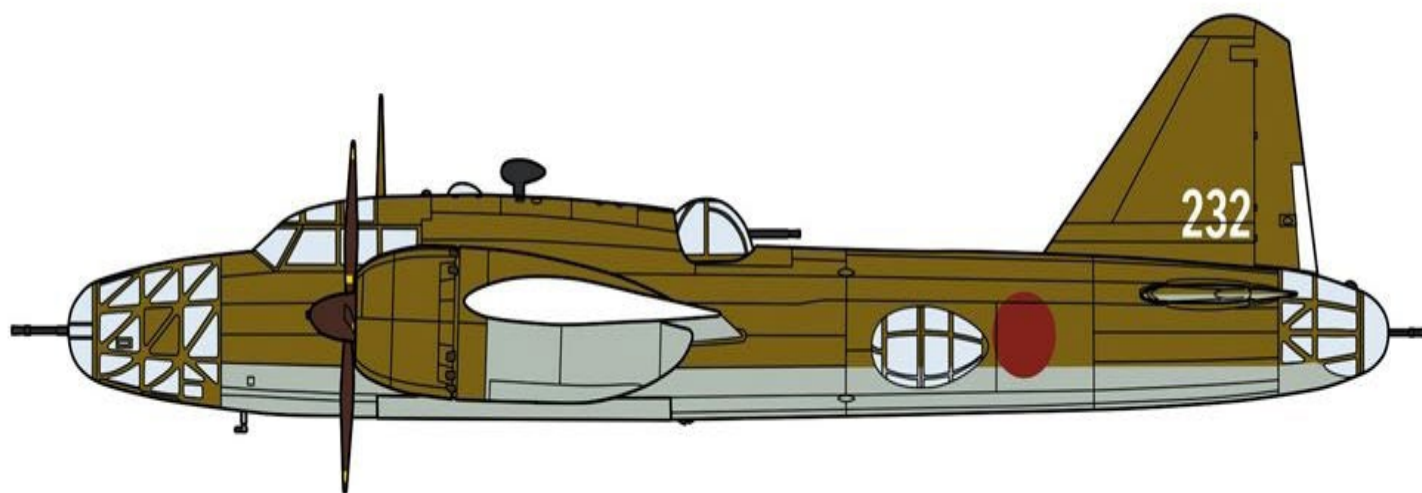

Platz is re-releasing its F-15J Eagle in Tactical Fighter Training Group markings.

希少なイーグル単座型アグレッサー塗装!  
ブルーのF-15J 903号機を再現!!



飛行教導隊時代最後を飾る  
青い塗装機のマーキングを  
デカール化!



1/144th Scale:

Revell is re-releasing their A340 Airbus as an A340-300 in Lufthansa New Livery



Revell

LEVEL 4

1:144

❖ 114 PARTS

↔ 44,1 cm

↔ 41,8 cm

Airbus A340-300

Lufthansa New Livery



1/200th Scale:

Hasegawa has re-released their EC-1 in Electronic Warfare Operation Group markings.



PHOTO: HAJIME ISHIHARA

**Kawasaki EC-1 'ELECTRIC WARFARE SQUADRON'**

LIMITED EDITION

※実際の製品パッケージとは一部異なる場合がございます。

And there you have it for May. Go build a model!

## Shipping News

by Rick Herrington

Ahoy mates! Welcome to the menagerie of Naval Modeling. A smattering of new releases this month including a couple in 1/200 scale and 1/72nd scale. Let's start off with 1/700 scale. First from Hobby Boss is a PLAN Type 094 SSBN.





Aoshima is releasing the USS Washington one of the fast battleships.



Moving on to 1/350 scale Trumpeter is releasing the French helicopter carrier Jeanne D'Arc.



Riich Models is releasing an Ohio class SSGN which includes a Seal Delivery Vehicle.



Trumpeter is also releasing the WW 2 French light cruiser Georges Leygues.



Finally in 1/700 scale Kami De Korokoro is releasing a JMSDF observation ship the Nichinan.



Finally from Trumpeter is the USS Montana.



Finally in 1/350th scale Veryfire is releasing a IJN Yamato. This one will set you back a chunk of change but but the premium version has all the bells and whistles and has the added bonus of being engineered by Veryfire.





B54

A17



A17

B54



Complete

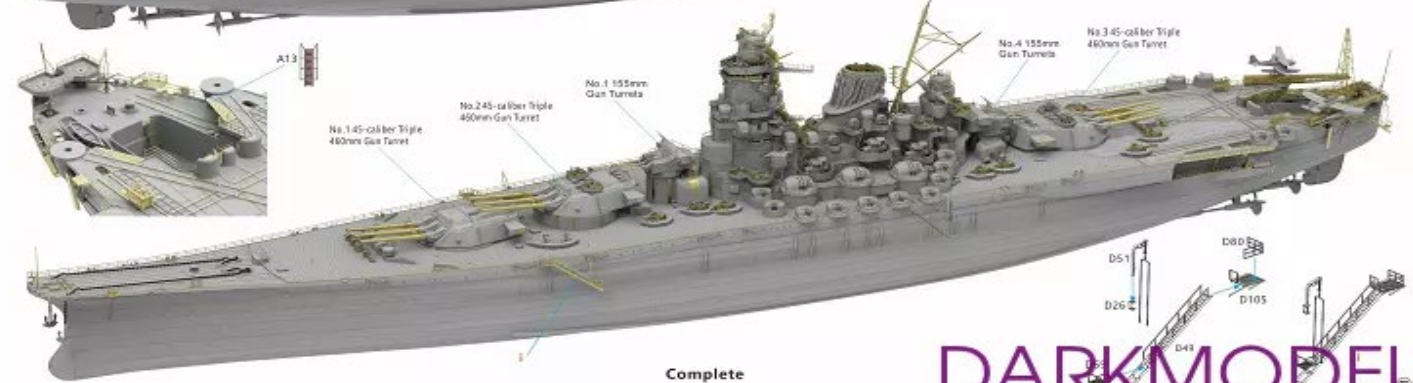

DARKMODEL®

Moving on to shelf buster scale (1/200) we have two releases, both from I Love Kit. The first is the USS Pinkney.

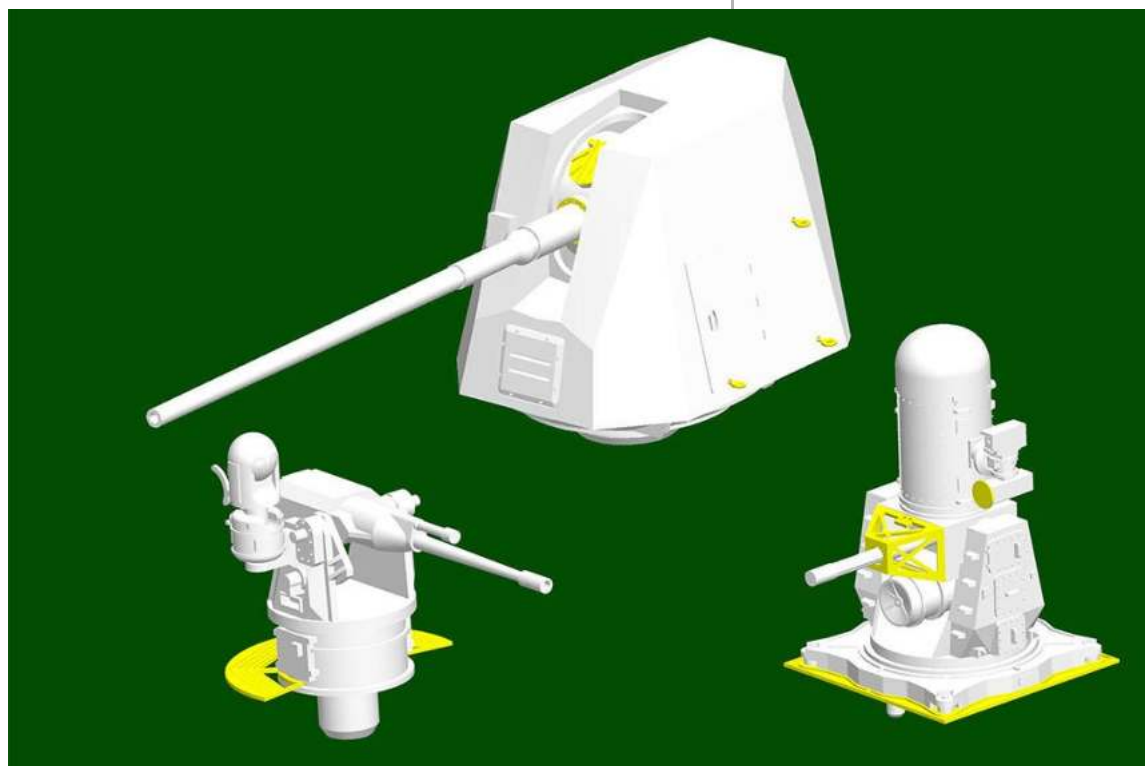

The second from I Love Kit is DDG-54 Curtis Wilbur.



Last entry in the ship column is in 1/72 scale. ICM is releasing a set of K-Verbande midget submarines. K-Verbände, full name Kleinkampfverbände der Kriegsmarine. Its tasks were to conduct sabotage and assault operations on rivers, at sea and in the coastal zone.

**MODEL KIT N° S.020**

**K-Verbände Midget Submarines**

**ICM**  
*More in the Stash*

**1:72 SCALE**

- Two models of ultra small submarines of the Kriegsmarine fleet
- Geometric proportions of real prototype submarines are clearly reproduced
- Submarine hulls have high level of detailing – hull plating and individual elements
- Decals with four different markings for "Mold" and two for "Seehund"

That's all the wind in the sails for this month. Grab a kit out of that stash and build it!

# Tracked Topics

By Panzer Lehr

Strictly 1/35 and 1/16th this month. First up is AFV Club with an Australian M113A1



Amusing Hobby has a couple of new releases for us this month. The first is a Russian Black Eagle Object 640. This tank never entered production and was a test bed for cutting edge Russian tank design. It was based on the T-80U

Next from Amusing Hobby is a Leopard 2A8.





Hobby Boss is releasing a kit of the IDF Eitan. From what I understand this kit is based on the prototype of Israel's newest APC. It is different from the production vehicle that's being used in Gaza.



Meng is releasing a second version of its Merkava 4. This one includes turret slat armor that protects the tank from enemy drones.



MENG  
WWW.MENG-MODEL.COM

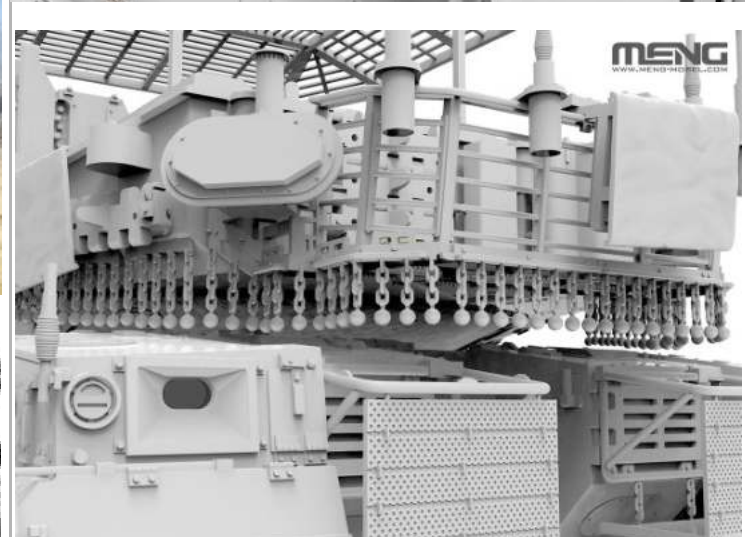

Meng's Merkava includes the trophy active protective system.

Model Miniature is releasing an EBRC Jaguar. This is a new French recon vehicle.



Takom is releasing....wait for it....another...Woo Hoo! Tiger 1 kit. This one is a Gruppe Fehrman (1945) version. Apparently the manufacturers believe the saturation point on Tigers hasn't been reached yet.



Tiger Models is releasing their own Tiger 1



Trumpeter is releasing the Vbm Freccia an Italian 8 wheeled armored car.



RFM is releasing a late model Panther G with steel wheels and roof armor.



Takom is releasing an M247 Sargeant York. I wish I could say this was a long anticipated release, but at least it's not another Tiger.



Tamiya is releasing/re-releasing? their M1A2 in 1/16th scale. The box says it's a display model. Scalemates says this was originally designed for RC.

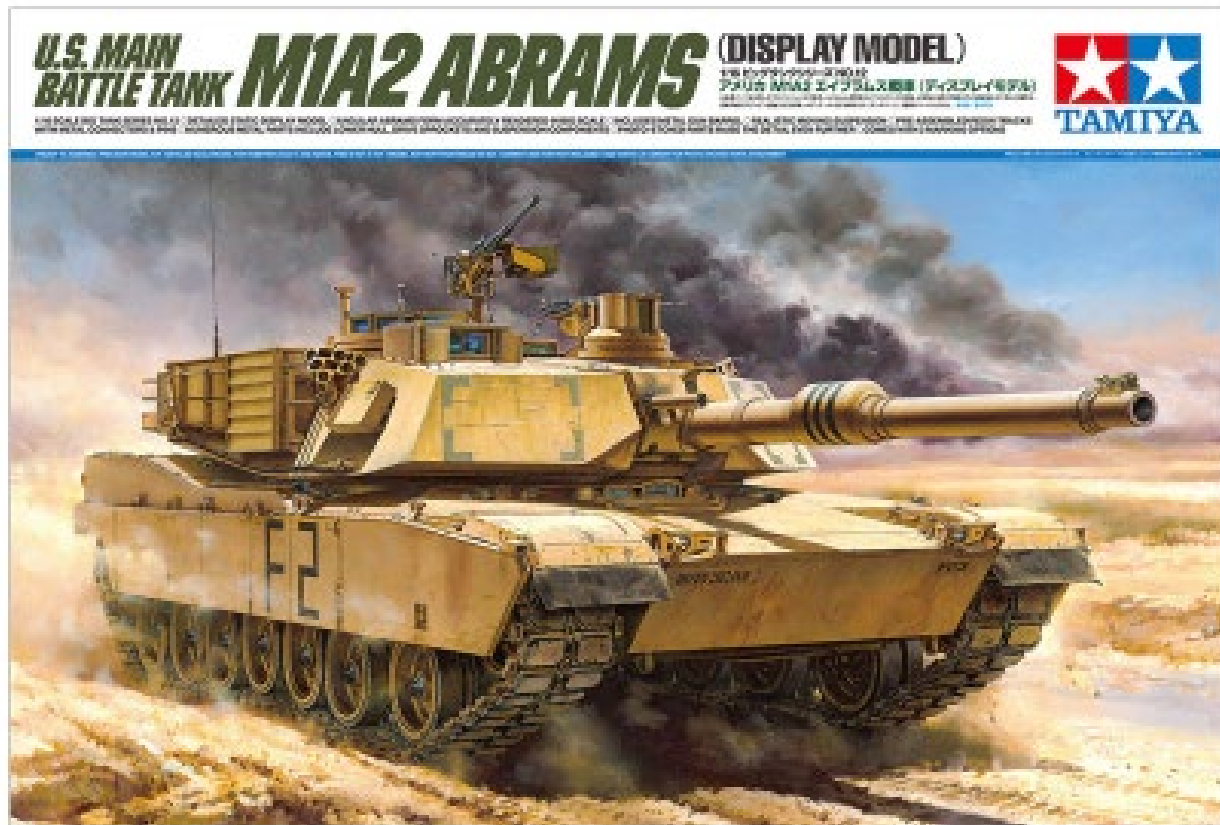

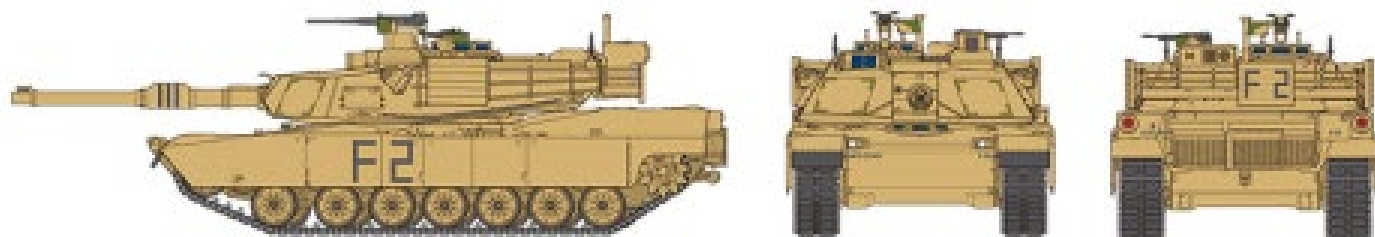

第3機甲騎兵連隊 第2大隊 F 中隊 第2小隊所属車 2003年 4月イラク

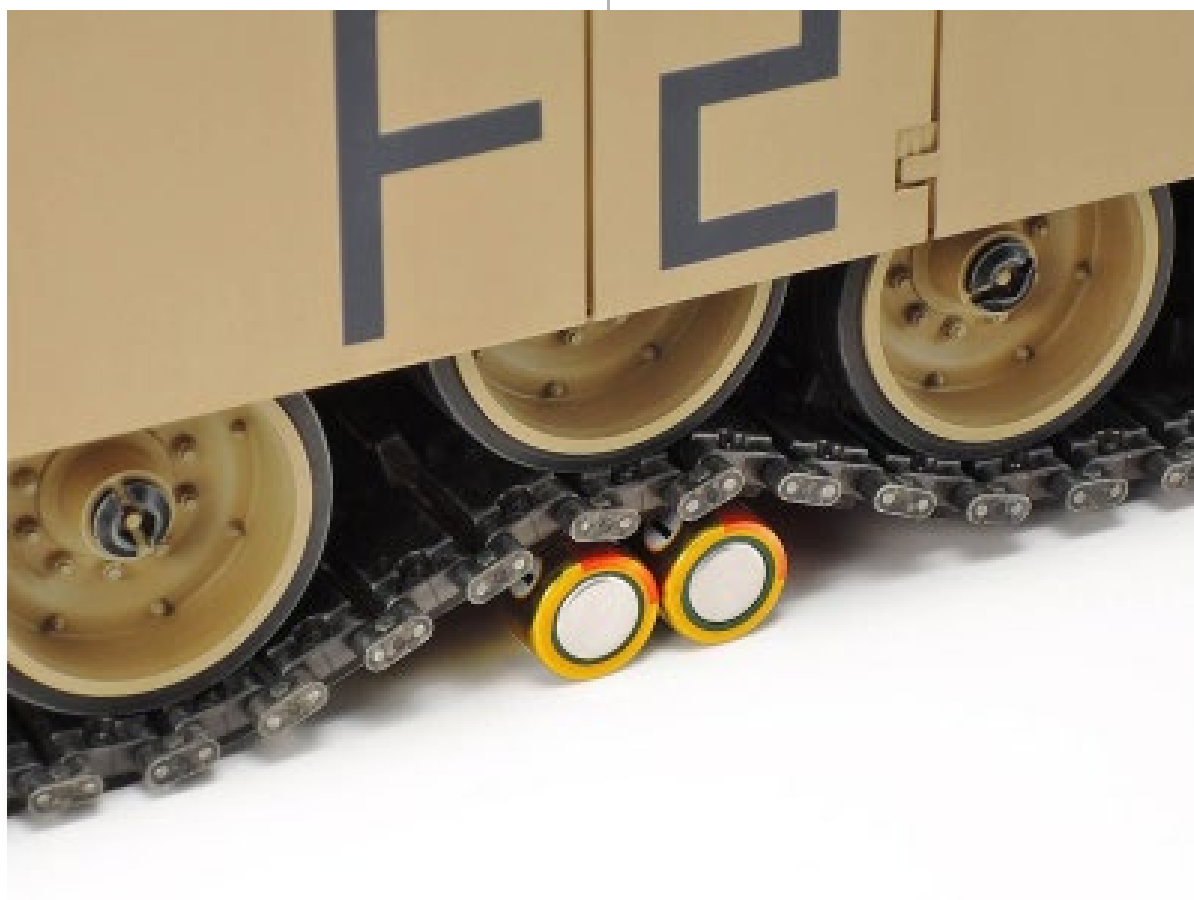

Sticking with 1/16th scale Andy's Hobby is releasing an M113A1 Acav.

# M113A1 / M113A1 ACAV ARMORED PERSONNEL CARRIER 2in1



**1/16 SCALE**  
AHHQ 009



# M113A1/M113A1 ACAV ARMORED PERSONNEL CARRIER 2in1

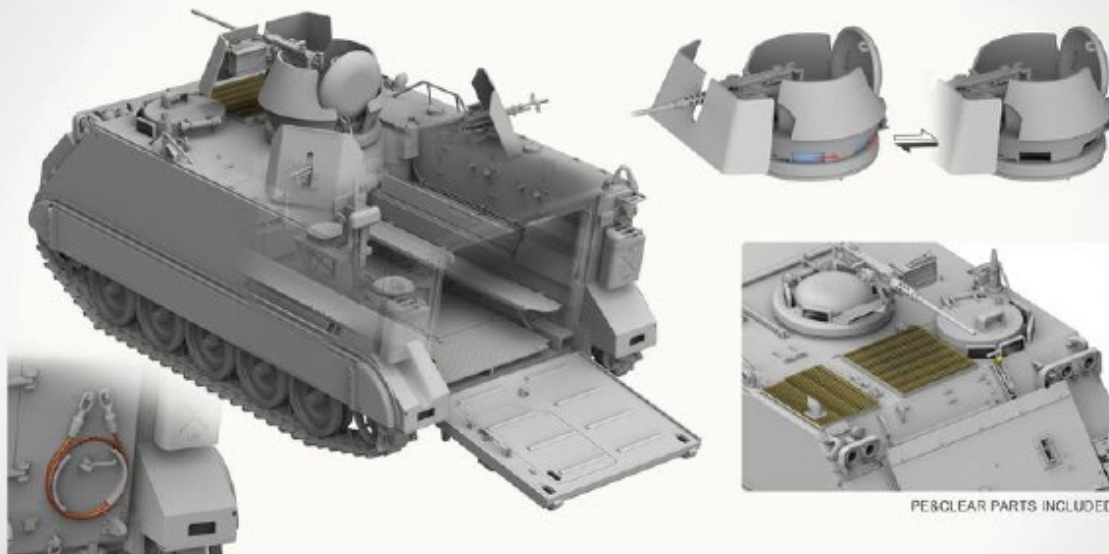

PE&CLEAR PARTS INCLUDED

**1/16 SCALE**  
AHHQ 009

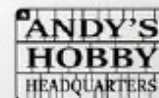

That's the armor column for this month. See you at the meeting!

IPMS USA is soliciting articles. We've got some great modeller's in this area and you can help the mother organization to flourish by submitting an article to the Journal.

**ARTICLES WANTED!**

**WE WANT TO KNOW WHAT YOU ARE BUILDING**

Maybe you build cars. Or jets. Or figures. Or tanks. Maybe you slap em' together. Maybe you count every rivet.

**How did you built it?  
What makes this particular subject interesting?  
Do you have any special tricks?**

Any IPMS USA member can submit an article on any modeling related topic to the IPMS USA Journal  
The standard word count is 3000 and it should be well documented with high resolution photos  
Send inquires to: [ipms-q@ipmsusa.org](mailto:ipms-q@ipmsusa.org)

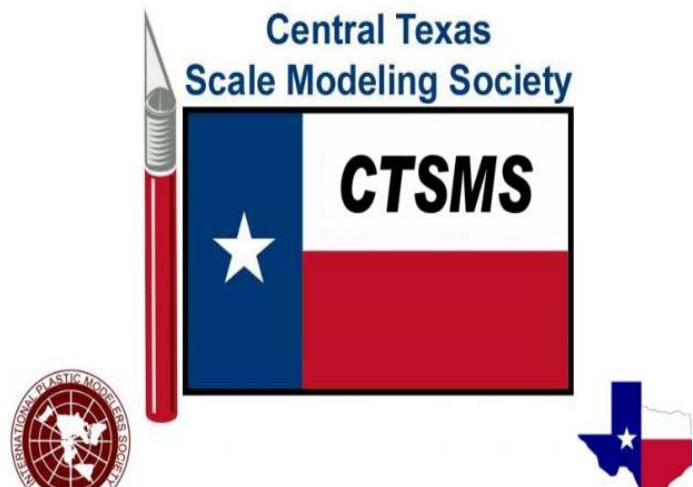
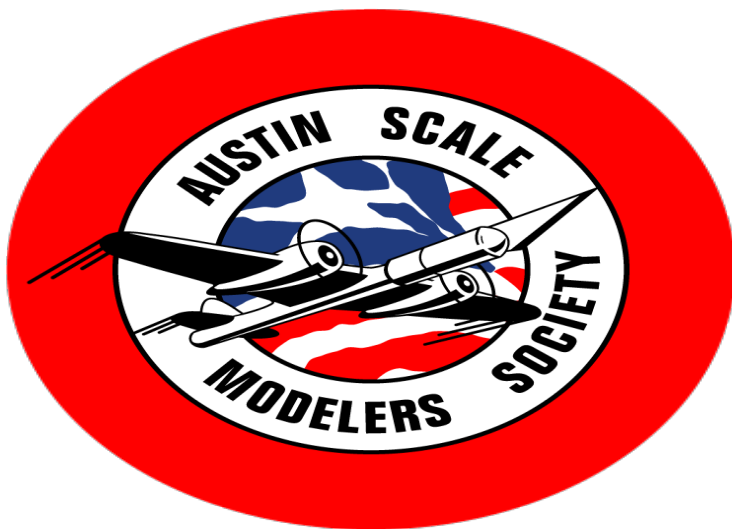

# Something for Everyone!



7801 N. Lamar Blvd., Ste B169,  
Austin, TX 78753  
(512) 836-7388



[kinginfo@kingshobbyshop.com](mailto:kinginfo@kingshobbyshop.com)

<http://www.kingshobbyshop.com>







## Join International Plastic Modeler's Society / USA

IPMS/USA is dedicated to the hobby (and fun) of Scale Modeling. It was started by Jim Sage, of Dallas, Texas, in 1964. There are now branches of IPMS all over the world. Our Local Regions and Chapters sponsor Model shows and contests every year, but you needn't be a member to visit the shows or attend the club meetings!

With IPMS/USA Membership, you will receive the outstanding IPMS/USA Journal six times a year - it includes features on all modeling subjects such as aircraft, armor, automotive, ships, figures - you name it! You will also find listings of IPMS contests, swap meets, hints and tips, and reviews. Membership also qualifies you to participate in IPMS/USA sanctioned contests, and particularly in our World-famous National Convention, held each summer. As a member, you'll also be able to access our online Discussion Board, where a wide variety of modeling topics are discussed, and enjoy interaction with other serious modelers for help with questions about modeling techniques or the Society in general. Many Hobby Shops and Model Vendors around the USA offer discounts to IPMS/USA Members.

Visit us at: <http://www.ipmsusa.org/>  
Join up online at: <http://www.shopipmsusa.org/category-s/100.htm>

For any questions or problems with your membership application/renewal, please contact the IPMS/USA Officer Manager at [manager@ipmsusa.org](mailto:manager@ipmsusa.org)

International Plastic Modelers' Society/USA

Membership Application / Renewal Form

New  Renewal  IPMS#: \_\_\_\_\_

Name: \_\_\_\_\_

\_\_\_\_\_

Address: \_\_\_\_\_

\_\_\_\_\_

City: \_\_\_\_\_ State: \_\_\_\_\_ Zip Code: \_\_\_\_\_

\_\_\_\_\_

Phone: \_\_\_\_\_ E-Mail: \_\_\_\_\_

\_\_\_\_\_

Chapter Affiliation, if any: \_\_\_\_\_

Junior (17 years or younger)  \$17.00 Date of Birth \_\_\_\_\_

Adult One year  \$30.00

Two years  \$58.00

Three years  \$86.00

Canada & Mexico  \$35.00

Foreign Surface  \$38.00

Family  Adult fee + \$5.00

# of cards? \_\_\_\_

Your Signature: \_\_\_\_\_

If recommended by an IPMS member, please provide his/her:

Name: \_\_\_\_\_ IPMS #: \_\_\_\_\_

PAYMENT OPTIONS:

Cash  Amount: \_\_\_\_\_

Check  Check #: \_\_\_\_\_ Amount: \_\_\_\_\_

Where did you hear about IPMS/USA? Please check all that apply:

Local model club

Friend

Ad in IPMS Journal

Facebook

Ad in other magazine

Internet search

IPMS web site

I'm a former member rejoining

Other \_\_\_\_\_

Applications should be printed and mailed to:

IPMS/USA

P.O. Box 1411

Riverview, FL 33568-1411

# LIONHEART HOBBY

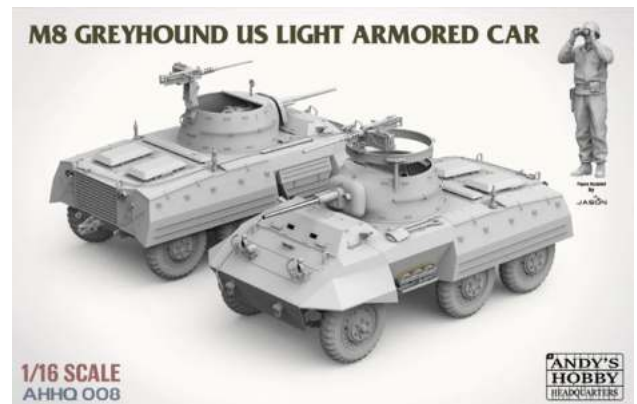
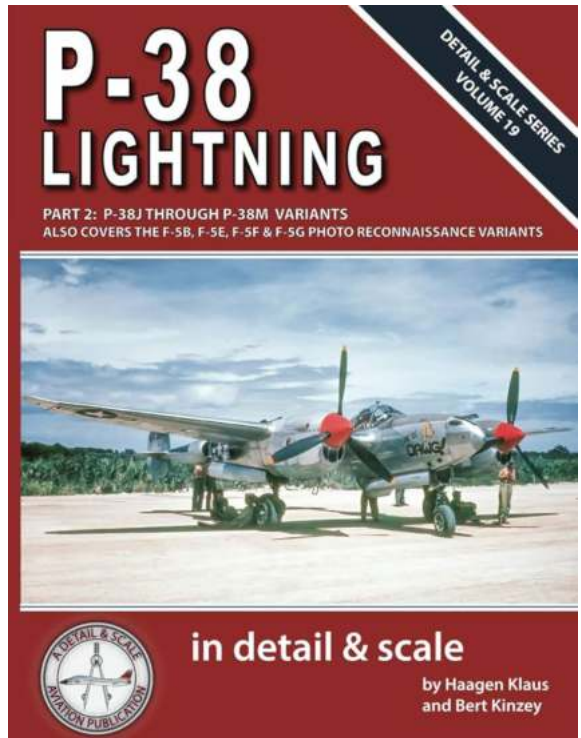

5500 Jack C Hays Trail, Kyle, Texas 78640,  
(512) 504-3404  
10:00 am – 06:00 pm



**Austin's premier source for  
comics and gaming.**

**2024 SUMMER  
CAMPS!**  
**-SIGN UP TODAY-**



**PRERELEASE  
EVENT**

**FLESH  
AND  
BLOOD**

**SATURDAY  
MAY 25TH**

**Part the Mistveil**

**MAGIC**  
THE GATHERING  
**COMMANDER LEGENDS**  
**DUNGEONS & DRAGONS**  
BATTLE FOR BALDUR'S GATE  
**COMMANDER  
DRAFT**

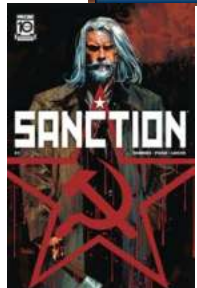

**2438 W. Anderson Ln,  
Suite B-1  
Austin, TX 78757**